



领先的中国色彩与光泽分析专家  
China's leading expert of color and gloss analysis



# 分光色差仪

产品使用说明 ▶  
CS-280/280+/286/288

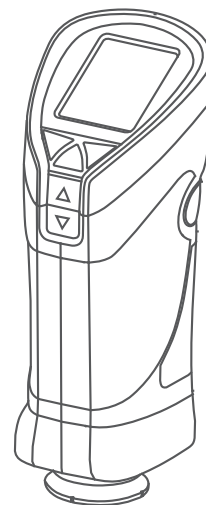

服务热线：4007-7272-81

**杭州彩谱科技有限公司**  
HANGZHOU CHNSPEC TECHNOLOGY CO.,LTD

地址：浙江省杭州市江干区文渊北路166号  
电话：4007-7272-81 传真：0571-85888727

[www.hzcaipu.com](http://www.hzcaipu.com)

# CATALOGUE

## 目录

[一]分光色差仪使用须知	1
[二]注意事项	1
[三]色差仪功能描述	1
[四]技术参数	2
[五]仪器外观结构介绍	3
[六]测量流程图	5
[七]校准页面	6
[八]主页面	6
[九]测量	7
9.1 标样测量	7
9.2 试样测量	8
[十]数据查看	9
[十一]设置	10
11.1 校准	10
11.2 测量设置	11
◆ 显示	12
◆ 光源	12
◆ 容差	13
◆ 平均	13
◆ 保存	14
11.3 系统设置	14
◆ 语言选择	15
◆ 时间设置	15
◆ 电源管理	16
◆ 恢复出厂	16
11.4 加标样	17
11.5 版本	17
[十二]USB通信	18
[十三]定制功能	18
13.1 摄像头取景功能	18
13.2 色卡录入	19
[十四]产品配件图	22
[十五]异常处理	23
[十六]测量结果分析	23
[十七]公司声明	24

## 分光色差仪使用须知

- 1、本说明书所述“色差仪”指的是分光色差仪。
- 2、本说明书所述“标准黑腔”、“标准白板”指与色差仪配套，用于仪器校准的工作标准器件。
- 3、本仪器使用应避开强电磁干扰。
- 4、本说明书中提及的L、A、B、C、H指GB/T 7921-2008中规定的CIELAB色空间中的 $L^*$ 、 $a^*$ 、 $b^*$ 、 $C^*$ 、 $h$ 。

## 注意事项

- 1、本机属精密仪器，不能承受因跌落而导致的碰撞，使用时请放置于相对平整的地方。
- 2、本机不能防潮或抗潮，受潮或液体溅入易损坏本机。
- 3、本机的屏幕是由玻璃制成，受到异常外力或锐器的作用易损坏。
- 4、本公司建议使用原配电源适配器。
- 5、为保障本机正常工作，请不要在过冷或过热的地方存贮和使用，也勿将本机放置在潮湿或阳光长期直射的地方，更不要在高强震等恶劣的环境中使用本机，以免发生意外。
- 6、色差仪是精密仪器，使用时请避开强电磁干扰。
- 7、为保证测量准确，请不要用本机测量不平整的表面。
- 8、为保证测量准确，测试时请保持仪器平稳，不要摇晃。
- 9、测试时请将仪器的测试口紧贴测试物体表面，但不要用力按压。
- 10、本机属精密仪器，使用完毕请将仪器装入软包内保管。
- 12、本机及说明书如有进一步改进或补充，恕不另行通知。如有疑问，敬请垂询本公司。

## 色差仪功能描述

- 1、比较样板与被检测品之间的颜色差异，输出样板和被检测品的颜色差异，可以测量XYZ、RGB、 $L^*a^*b^*$ 、 $L^*C^*h$ 数据、查看Yxy色空间图和比较后的 $E^*ab$ 、 $L^*$ 、 $a^*$ 、 $b^*$ 、 $C^*$ 、 $h$ 色差数据。
- 2、人性化设计、良好的人机交互界面。
- 3、可存储20000条测试记录，其存储的结构为：100条样品，每种样品可保存200组相对该样品的色差数据。
- 4、数据浏览功能。
- 5、具有低电能提示功能，存储数据空间满提示功能。
- 6、USB通信功能。
- 7、可连接微型打印机。

## 技术参数

型号	CS-280	CS-280+	CS-286	CS-288
照明方式	di/8(散射光源, 8度观测角)SCI(符合 CIE No.15、ISO 7724/1、ASTM E1164、DIN 5033 Teil7、JIS Z8722 Condition c 标准)			
积分球尺寸	40mm, Avian-D全漫反射表面涂层			
照明光源	CLED			
感应器	阵列传感器			
测量波长	400~700nm			
光谱分辨率	10nm			
测量时间	2秒			
测量口径	11mm, 可选4mm、6mm、15mm			
重复性	标准偏差 $E^*ab$ 0.08 (校正后, 以间隔10s测量白板30次标准偏差)			
观察条件	2°、10° 观察角			
观察光源	A、C、D50、D65		A,C,D50,D55,D65,D75,F1,F2,F3,F4,F5,F6,F7,F8,F9,F10,F11,F12,DLF,TL83,TL84,NBF,U30,CWF,U35	
显示内容	样品色度值 ( $L^*a^*b^*$ , $L^*C^*h$ ), 色差值, 合格判定, 颜色偏向, 平均值, 生成检测报告, 光谱图   显示测量区域   显示测量区域, 光谱数据, 手动输入标准样			
色差公式	$E^*ab$ , $E^*CH$		$E^*ab$ , $E^*CH$ , $E^*uv$ , $E^*cmc(2:1)$ , $E^*cmc(1:1)$ , $E^*94$ , $E^*00$	
颜色空间	$CIE-L^*a^*b^*$ , $L^*C^*h$	$CIE-L^*a^*b^*$ , $L^*C^*h$ , XYZ, Yxy	$CIE-L^*a^*b^*$ , $L^*C^*h$ , $L^*u^*v$ , XYZ, Yxy, 反射率	
其他色度指标	沾色牢度, 变色牢度	WI(ASTM E313-10, ASTM E313-73), CIE/ISO, AATCC, Hunter, Taube Berger, Ganz, Stensby) YI(ASTM D1925, ASTM E313-00, ASTM E313-73) Tint(CIE, ASTM E313, Ganz)	沾色牢度, 变色牢度	同色异谱指数Milm, 沾色牢度, 变色牢度
数据存储	20000条测试数据			
光源寿命	5年150万次			
其他功能	摄像头取景、色卡建库		摄像头取景、色卡建库、手机APP	
显示屏	全色真彩屏			
语言	中文、英文			
端口	USB2.0		USB2.0、蓝牙	
操作温度	5~45 °C, 相对湿度 80% 或更低 (在 35 °C 下), 无水气凝结			
存储温度	-25 °C 到 55 °C, 相对湿度 80% 或更低 (在 35 °C 下), 无水气凝结			
电源	可充电锂电池 8.4V/2000mAh, 专用适配器DC12V			
尺寸	77 × 86 × 210mm			
重量	550g			
标准附件	电源适配器、说明书、颜色管理软件、驱动软件、说明书电子版、颜色管理教程、数据线、黑白校准、保护盖、便携包、电子色卡			
可选附件	微型打印机			
配色系统	不可配			
UV光源	不含UV光源			

## 仪器外观结构介绍

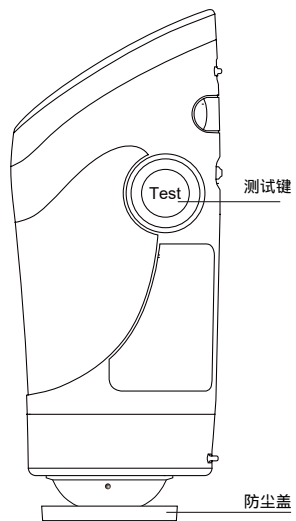

右视图

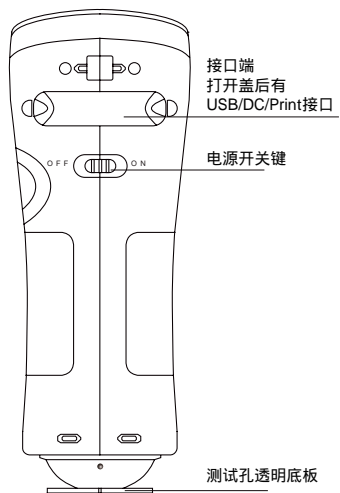

背视图

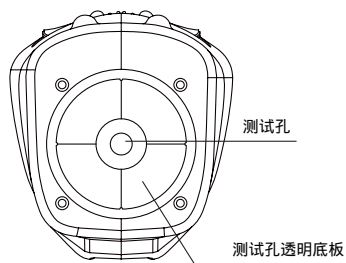

底视图

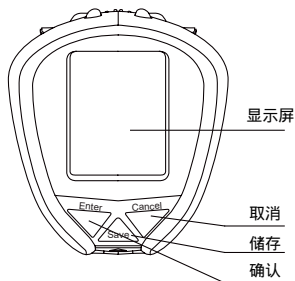

顶视图

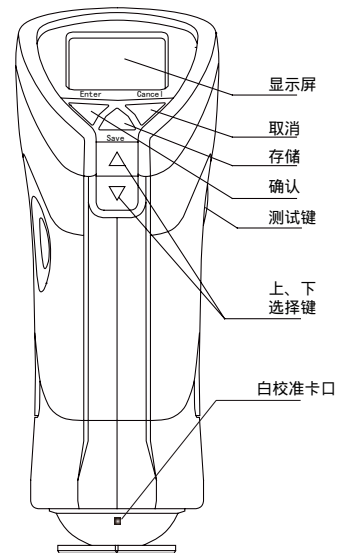

正视图

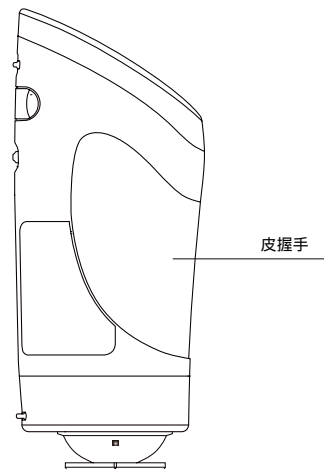

左视图

## 测量流程图

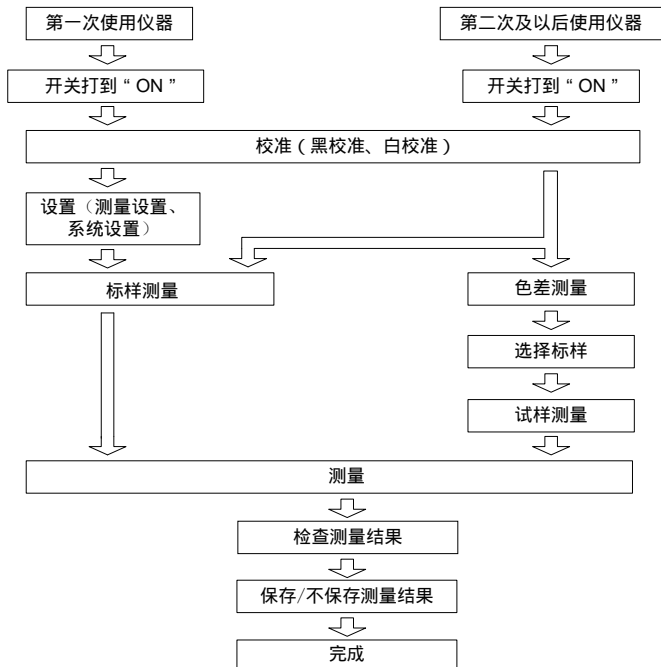

## 校准页面



- A** 开关打到“ON”后，仪器自动进入校准页面。在该页面下，需先对仪器进行黑白校准。将仪器底部上防尘盖摘下，将黑腔上面的盖子旋转开，把仪器底部放入黑腔内。通过“Up”、“Down”选择“黑校准”，按“Enter”键，短鸣“滴”声后完成黑校准。白板旋转与仪器扣紧，把仪器放平稳，通过“Up”、“Down”选择“白校准”，按“Enter”键，短鸣“滴”声后完成白校准。校准完成后，按“Cancel”键退出校准页面，进入程序主页面。
- 注：为了保证仪器稳定性，建议每次开机都进行黑白校准。

## 主页面

- B** 主页面：
- 标题栏：显示当前页面的主要功能信息。
- 工作区：显示页面下属于菜单的主要功能或是测试时的数值。

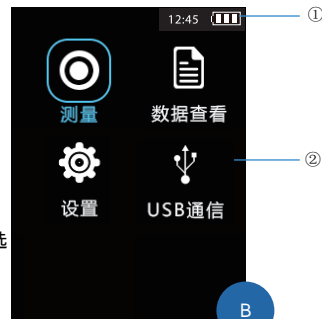

### 程序基本操作方法：

通过“Up”、“Down”上下选择键，选择相应的功能按钮，按“Enter”键进入选择的界面进行相应操作，按“Cancel”键返回上一步骤，按“Save”键对测试结果或状态设置进行保存。

**测量：**用户可以测量样品的各项颜色参数，完成样品与标样之间的颜色差异测试，以及查看所保存的测试记录等。

**校准：**用户可在使用仪器前先对仪器进行黑、白校准。

**数据查看：**在该页面中用户可以查看已保存的标样下的各项参数。并可对选择的样品进行删除、编辑名称等操作。

**设置：**用户可以对仪器测量条件的各项参数进行选择 and 设置。

**USB通信：**用户可以通过USB接口与PC机连接进行数据传输，以及进行上位机操作。

## 测量



- B-1** 在主页面，通过Up、Down选择键,选择“测量”图标，按“Enter”键进入“标样测量”页面。在该页面下，用户可以测量标样的色空间、色度指标参数。还可以测量标样与试样之间的色差，以及查看对试样合格与否的判断。

## 标样测量

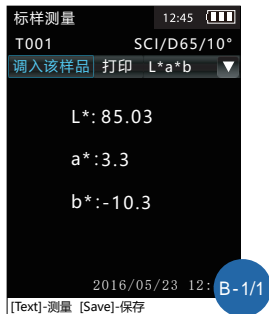

- B-1/1** 将仪器测试口紧压待测样品表面，按“Test”键，“嘀”声后完成测量，查看测量结果。
- 测试结果的标题栏中，分别显示了标样名称和测试结果的测试条件。标样未保存时，标样名称一律显示为“Txxx”，当按“Save”键保存标样后，名称显示为保存之后的标样名。测试条件格式：SCI为测量条件/D65为光源/10°为观察者。通过Up、Down选择键，还可对测试结果进行“调入该标样”、“打印”，选择显示内容（包括“L\*a\*b\*”、“L\*C\*h”、“X,Y,Z”、“Y,x,y”、光谱反射率。

“调入该标样”：进入“试样测量”页面，以当前测试数据为标样，与试样测试结果对比测量色差。

“打印”：对测试结果的数据进行打印。

选择显示的内容，可通过“Enter”键进入选择菜单，通过Up、Down键选择查看测量样品的色空间参数、色度指标参数等信息，具体包括“L\*a\*b\*”、“L\*C\*h”、“X,Y,Z”、“Y,x,y”、光谱反射率。

## 试样测量



- B-1/2** 在上面的标样测量完成并保存后，选择“调入该标样”，按“Enter”键进入“试样测量”页面。该界面下以当前测试数据为标样，再按“Test”键测试，新测量的样品为试样，“嘀”声后完成色差测量，显示色差结果。再次按下“Test”键可进行新的色差测量。与标样测量相同，试样测量在未保存时，在测试结果的标题栏中，试样名称显示为“Sxxx”，保存后则显示为保存后的名称。
- 在“数据查看”界面下，同样也可以进行色差测量。通过Up、Down键选择已有的标样，按“Enter”键进入选择菜单，选择“查看详细”，查看所选的标样数据。然后在“查看标样”页面下，按“调入该标样”，进入该标样下的“试样测量”页面，按“Test”键进行测量，“嘀”声后完成色差测量，查看测量结果。再次按下“Test”键进行新的色差测量。

注：色差测量前请先设置容差。（参看 设置 测量设置 容差设置）

在“试样测量”页面中，通过Up、Down选择键，还可对色差测试结果进行“打印”，选择显示内容（包括“L\*a\*b\*”、“E\*ab”、“L\*C\*h”、“Ech”、“X,Y,Z”、“Y,x,y”、光谱反射率）等操作。通过Up、Down选择键选择要查看的内容，包括测量样品与标样之间的色空间参数、色度指标参数，以及合格/不合格判断、偏色详情评价。

## 数据查看

- C 在主页面，通过Up、Down选择键,选择“数据查看”图标，按“Enter”键进入“数据查看”页面。在该页面下，用户可以查看已保存标样信息、试样信息以及色彩仿真等。



[Up,Down]-选择 [Enter]-菜单

通过Up、Down选择键，选择所需查看的标样，按“Save”键弹出菜单窗，通过Up、Down选择键，进行查看详细、查看试样、删除、编辑名称等操作。  
查看详细：查看所选标样的详细数据所有色差测试记录。可在该页面下按“调入该标样”进入该标样下的试样测量，进行新的色差测试。  
查看试样：查看所选标样下的所有试样测试记录。按“Save”键即可在弹出如图所示的菜单窗，对所选测试记录进行查看详细、删除、删除所有、编辑名称等操作。  
删除：将删除该标样及标样下的所有色差测试记录。  
编辑名称：编辑更改所选样品的名称。

## 设置

- D 在主页面下，通过Up、Down选择键，选择“设置”图标，按“Enter”键进入“设置”页面，有校准、测量设置、系统设置、加标样、版本五个内容。



## 校准

- E 在主页面，通过Up、Down选择键,选择“校准”图标，按“Enter”键进入“校准”页面。在该页面下，用户可以进行黑校准、白校准。



[Test]-校准 [Cancel]-退出

黑校准：仪器底部上防尘盖摘下，将黑腔上面的盖子旋转开，把仪器底部放入黑腔平放。通过“Up”、“Down”选择“黑校准”，按“Enter”键，短鸣“滴”声后完成黑校准。校准成功后，提示“黑校准成功！”。



**E-1** 白校准：白板旋转与仪器扣紧，把仪器放平稳，通过“Up”、“Down”选择“白校准”，按“Enter”键，短鸣“滴”声后完成白校准。校准成功后，提示“白校准成功！”。

**F-1** 显示设置：通过Up、Down选择键选择“显示设置”，按“Enter”键进入显示设置页面。按Up和Down键，选择您需要显示的色空间、色坐标或者指数，按Enter键确认。当您选择某一项后，测量页面将显示您所选的内容。

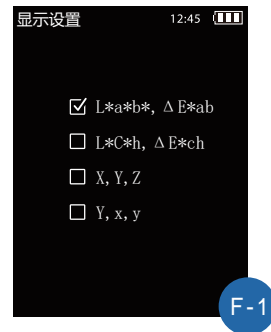

**F-2** 光源选择：通过Up、Down选择键选择“光源选择”，按“Enter”键进入光源设置页面。本页面下可以选择在测量页面显示任一种光源下的测量数据。本仪器提供A光源、C光源、D65光源三种光源。通过Up和Down键进行选择光源选择。

## 测量设置

**F** 通过Up、Down选择键，选择“测量设置”图标，按“Enter”键进入“测量设置”页。

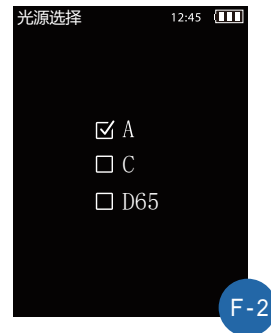

- F-3 容差设置：通过Up、Down键选择“容差设置”，按“Enter”键进入容差设置页面。Up、Down键修改数值，按“Enter”键确认。



- F-5 保存设置：通过Up、Down键选择“保存”，按“Enter”键进入保存页面。Up、Down键选择手动保存或自动保存，按“Enter”键确认，其中勾选自动保存后每次标样测量与试样测量均会自动保存（例如显示为T040和S001），而勾选手动保存则不会自动保存（即显示为Txxx和Sxxx）。



- F-4 平均设置：通过Up、Down键选择“平均设置”，按“Enter”键进入平均设置页面。Up、Down键修改平均测试次数，按“Enter”键确认。

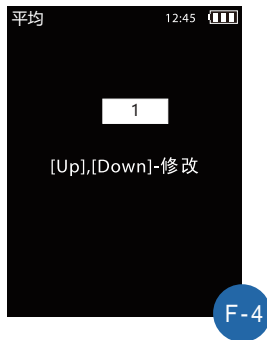

## 系统设置

- G 通过Up、Down选择键选择，按“Enter”键进入该“系统设置”页面。“系统设置”页面中可进行：语言设置、时间设置、电源管理、恢复出厂、查看版本等操作。



- G-1** 语言选择：通过Up、Down选择键选择“语言选择”，按“Enter”键进入语言设置页面。本仪器提供英文、中文两种界面语言，通过Up、Down键选择。



- G-3** 电源管理：通过Up、Down选择键选择“电源管理”，按“Enter”键进入电源管理页面。可对仪器的背光时间、关机时间进行修改设置。Up、Down键选择修改项，“Enter”键确认，再按Up、Down键修改数值，按“Cancel”键选择保存、退出。  
(注：背光时间设置为0时代表不关背光；关机时间设置为0时代表不自动关机)



- G-2** 时间设置：通过Up、Down选择键选择“时间设置”，按“Enter”键进入时间设置页面。设置修改本仪器的测量显示时间，可对年、月、日、时、分进行设置，Up、Down键选择修改项，“Enter”键确认，再按Up、Down键修改数值，按“Cancel”键选择保存、退出。

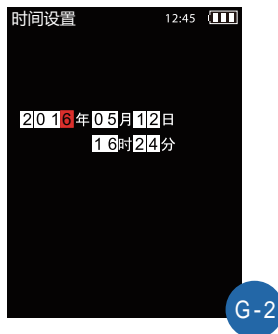

- G-4** 恢复出厂：通过Up、Down选择键选择“恢复出厂”，按“Enter”键进入恢复出厂页面。恢复出厂后，所有的数据将会被删除，并且设置系统将会恢复到默认设置。选择保存、退出。



## 加标样

- H 添加标样：通过Up、Down键选择“加标样”，按“Enter”键进入添加标样选择页面。通过Up、Down键和Enter键可选择多种颜色空间，具体设置所需要的颜色标量，然后进行添加，颜色模拟区域可对设置的标样提供直观的视觉参考。



H

## USB通信

- K 当USB线未插入USB接口或USB线与USB接口接触不良时，将如图显示。插入USB接口或重新插入即可正常连接，进行上位机操作。



K

## 版本

- I 版本：通过Up、Down选择键选择“版本”，按“Enter”键进入版本查看页面。显示本仪器的版本号信息，包括仪器型号、产品序列号、软件版本号以及公司名称。

(注：版本号若有更改，恕不另行通知。)



I

## 摄像头取景功能

- L 仪器若定制摄像头取景功能，在“测量”页面下，长按“Enter”键即可调出摄像头取景功能。通过观察摄像头取景框，移动仪器到所需测量的地方，即可以进行后续的测量功能。
- L/1 例如在标样测试下，长按“Enter”键查看测试位置并调出摄像头取景框。按“Cancel”键取消。

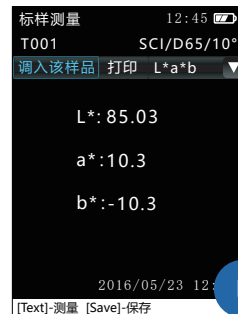

L



L/1

## 色卡录入

M-1

双击安装应用程序“Color Card.exe”。

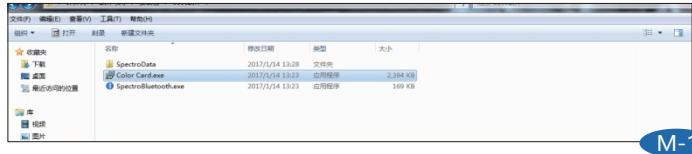

M-2

选择安装过程中要显示的语言。点击“确定”。

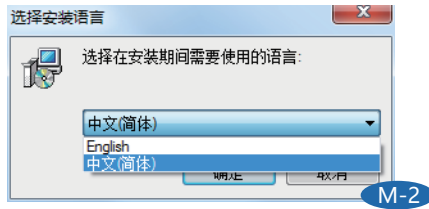

M-3

进入安装向导页面，点击“下一步”，开始安装。

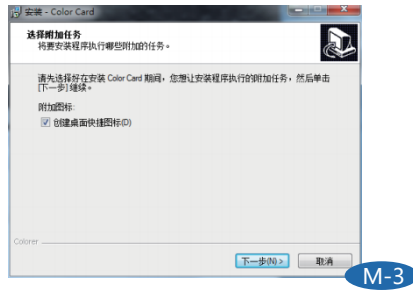

M-4

点击“安装”，等待完成Color Card安装向导。最后点击“完成”。

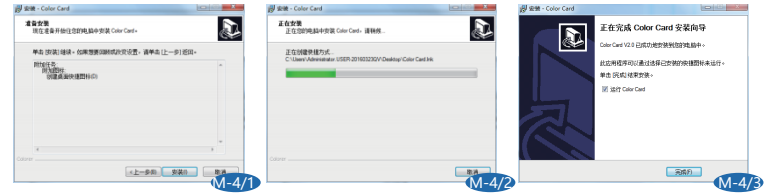

M-5

安装完成，打开“Color Card”应用程序。软件内置“PANTONE U”和“PANTONE C 15”两种色卡库。

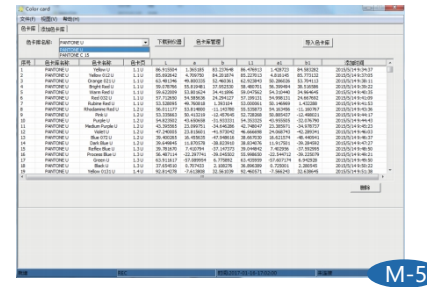

M-6

此时，将仪器通过数据线与计算机连接。点击“添加色卡库”，进行色卡库的添加。

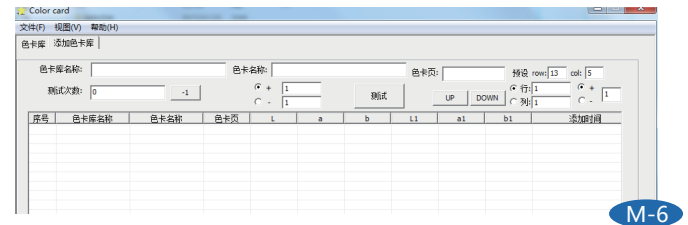

M-7

输入相应的色卡库信息。包括“色卡库名称”、“色卡名称”、“色卡页”、“预设行列数”等信息。

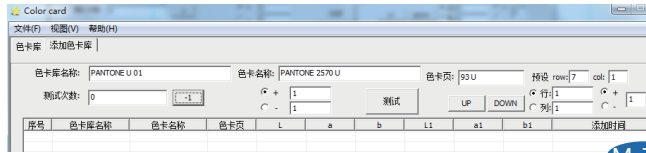

M-7/1

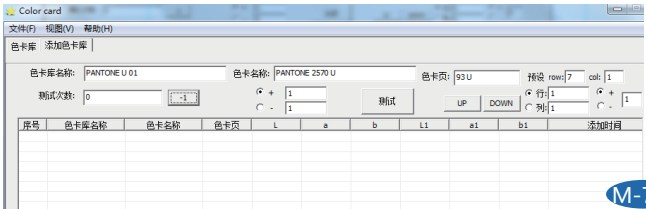

M-7/2

M-8

例如：

色卡库名称：PANTONE U 01 色卡名称：PANTONE 2570 U 色卡页：93 U

预设行列数：行=7 列=1 测试次数：0

将仪器测试孔对准相应色卡名称的色块进行测试，可点击软件页面的“测试”图标测试，也可直接按仪器上的测试按钮测试（注：测试时，仪器上不要退出“USB已连接”界面，否则会造成仪器与计算机断开USB连接）。每测一次，测试次数、色卡名称数字、行列数按预设数值进行相应递增递减，如图所示，各项按数值1递增。

如图设置，测量7次后，可通过点击“UP”、“DOWN”前翻或后翻色卡页数。此时也可按色卡所示更改色卡名称，或其他预设信息。

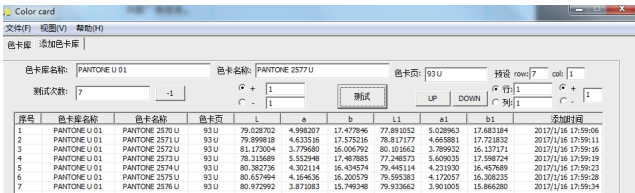

M-8

M-9

按以上操作依次录入色卡信息，待录入完毕，可将录入的色卡下载到仪器，也可通过“色卡库管理”删除软件内的色卡库，此外，软件也可导入xml文件格式的色卡库。

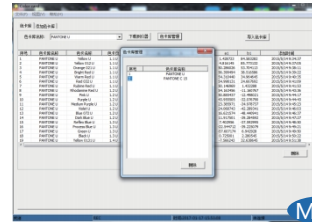

M-9/1



M-9/2

产品配件图

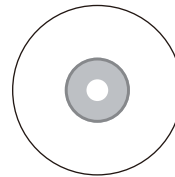

软件光盘

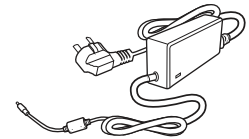

电源适配器

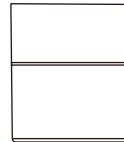

黑腔校准盒

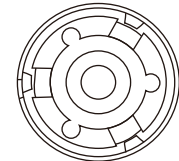

黑腔孔

开盖后黑腔校准盒顶视图

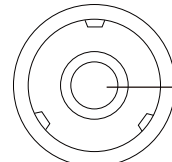

白板区

开盖后白板测试盒顶视图

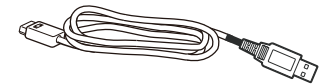

USB数据线

产品配件:	
白板	用于设备校准。
黑腔	用于设备校准。
外部供电电源	交流电源适配器的额定电流2A, 外部工作电压12V。
光盘	光盘里的软件, 为本仪器配套的上位机软件。
USB数据线	用于设备和PC机的通信。
微型打印机	为可选配件, 用于打印测量数据。

## 异常处理

异常情况	分析	处理方法
仪器无法开机	1、检查仪器是否连接到外部交流电源适配器 或是否装了干电池 2、检查电池电量是否充足	安装或更换干电池, 或连接电源适配器
开机后不能进入主程序	1、检查是否进行过黑、白校准 2、检查黑、白校准是否有误	重新进行黑白校准并再次进入
测量结果报错	检查容差设置是否合理	重新调整容差设置
测试数值异常	1、检查测量时仪器及测试品是否平稳, 测量口与测量面接触是否紧密良好 2、检查测量物体是否太薄漏光 3、检查测量部位是否是混色	1、保持仪器及测试品平稳 2、在测试品底部放置一个厚的塑料垫或 一张白纸 3、请测量单一颜色部分, 不要测量混色部位
两次测量结果相差较大	检查电池电量是否过低	更换新的干电池

## 测量结果分析

▼  $\Delta E$ 总色差的大小  $E^*ab = \sqrt{(L^*)^2 + (a^*)^2 + (b^*)^2}$

L+值表示偏白, L-值表示偏黑; a+值表示偏红, a-值表示偏绿; b+表示偏黄, b-值表示偏蓝。当一种颜色用CIE\*a\*b\*表示时, L\*表示明度值; a\*表示红/绿值及b\*表示黄/蓝值。

### ▼ CIE LAB

CIE LAB色空间是基于一种颜色不能同时既是绿又是红、也不能同时既是蓝又是黄这个理论而建立。所以, 单一数值可用于描述红/绿色及黄/蓝色特征。当一种颜色用CIEL\*a\*b\*表示时, L\*表示明度值; a\*表示红/绿值及b\*表示黄/蓝值。

### ▼ CIE LCH

CIE LCH颜色模型采用了同L\*a\*b\*一样的颜色空间, 但它采用L\*表示明度值; C\*表示饱和度和值及h表示色调角度的柱形坐标。

## 公司声明

本公司向用户承诺, 我们生产的色差仪系列产品, 保修期限为购买之日起的三年时间内有效, 正常使用情况下非人为造成的故障问题, 本公司将负责给予免费维修, 超过保修期或人为因素导致的故障, 本公司将提供维护, 将收取维修材料及相关费用。

本公司对于第三者因使用本产品引起的任何损失或索赔不负任何责任。

本公司对由于因故障、维修或断电造成的数据丢失而导致的任何损害或损失均不负任何责任。为防止重要数据的丢失, 请务必对所有重要数据进行备份。

本产品中预置的所有作品之版权归本公司所有, 受《中华人民共和国著作权法》保护。

我公司出售本产品的行为不代表向用户转让或授予与作品版权相关的任何权利。

本说明书所提到的产品规格及信息仅供参考, 内容会随时更新, 恕不另行通知。



China's leading expert of color  
and gloss analysis



## Spectral Colorimeter

OPERATION MANUAL  
CS-280/280+/286/288

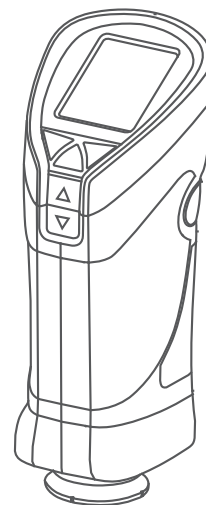

Service hotline:+86 571 85888707

Address:No.166,Wenyuan North Road,Jiangan District,Hangzhou City,China



Please do not disassemble the product without the assistance of customer support center, If you have any questions, please contact the local agency.

[www.chnspec.com](http://www.chnspec.com)

---

# CATALOGUE

---

[I]Term of Use	1
[II]Notes	1
[III]Instrument functions	1
[IV]Technical Parameters	2
[V]Appearance and structure	3
[VI]Measuring flow chart	5
[VII]Calibration page	5
[VIII]Main page	6
[IX]Measure	7
9.1 Target sample measure	7
9.2 Sample measure	8
[X]Data view	9
[XI]Settings	10
11.1 Calibration	10
11.2 Measure Setup	11
◆ Display	12
◆ Illumination	12
◆ Tolerance	13
◆ Average	13
◆ Save	14
11.3 System setup	14
◆ Language	15
◆ Set time	15
◆ Power	16
◆ Reset All	16
11.4 Add target	17
11.5 Version	17
[XII]USB	18
[XIII]Other optional function	18
[XIV]Camera View	18
[XV]Color Card Input	19
[XVI]Accessories	24
[XVII]Trouble Shooting	25
[XVIII]Testing Result Analysis	25
[XIX]Company's Statement	25

## Terms for use

1. The subject instrument of this manual is referred to as “spectral colorimeter” in this manual.
2. This “black cavity” and “white tile” mentioned in this manual is matching with instrument, used for calibration.
3. Keep away from the electromagnetic radiation when the instrument is working.
4. The L、A、B、C、H mentioned in this manual is L\*, a\*, b\*, C\*, h.

## Notes

1. The spectral colorimeter is a precise instrument, cannot afford to collisions in drop. Please place it at a smooth plane.
2. This instrument is not moisture proof or water resistance, it may be damaged if liquid splashed into it.
3. The screen of this instrument is made of glass; it is easily damaged by outside force.
4. Use the original power adapter.
5. Please do not place or use this instrument in a cold or hot environment, do not place this instrument in a humid or direct sun light environment, do not use this instrument in strong vibration or other harsh environment.
6. In order to ensure the accuracy of test, please check batteries carefully first.
7. Avoid testing on uneven surfaces.
8. Keep the instrument balance when working.
9. The instrument should be put closely on the sample surface.
10. Please put the instrument into the soft bag after using.
11. The information contained in this document is subject to change without notice.

## Instrument functions

1. Display color values by Lab, XYZ, RGB,  $\Delta L^*a^*b, \Delta L^*C^*h$ , display the difference values of sample and tested item by  $\Delta E^*ab, \Delta L^*, \Delta a^*, \Delta b^*, \Delta C^*, \Delta h, Yxy$ , Yellowness index and Whiteness index.
2. Use humanized design, friendly graphical user interface.
3. 20000 test records storage, data storage structure: 100 targets and 200 samples under each target.
4. Data browse.
5. Reminder for low battery and full memory.
6. USB communication.
7. Instrument can work with micro printer.

## Technical Parameters

Type	CS - 280	CS - 280+	CS - 286	CS - 288
Optical System	di/8(Diffused illumination , 8 degrees observe angle ) ( conform to CIE No.15, ISO 7724/1,ASTM E1164,DIN 5033 Teil7, JIS Z8722 Condition c standards )			
Light Source	CLED			
Sensor	Sensor array			
Spectral resolution	10nm , Spectral range ( 400~700nm )			
Measurement time	2s			
Measurement caliber	11mm , Optional:4mm,6mm,15mm			
Repeatability	E*ab 0.08 ( when a white calibrate plate is measured 30xat 10 - second intervals after white calibration )			
Language	Chinese and English			
Interface	USB2.0			
Observation angle	2 ° /10 °			
Measurement light source	A,C,D50,D65		A,C,D50,D55,D65,D75,F1,F2,F3,F4,F5,F6,F7,F8,F9,F10,F11,F12,DLF,TL83,TL84,NBF,U30,CWF,U35	
Display Mode	Chromaticity value ( L*a*b,L*C*h ) , delta E value,pass/fail,color tendency,average, generate test report,spectrum reflectance figure		with camera, spectrum reflectance data, manually input target sample	
Color differences	E*ab, E*CH		E*ab, E*CH, E*uv, E*cmc(2:1), E*cmc(1:1), E*94, E*00	
Color Spaces	CIE-L*a*b,L*C*h	CIE-L*a*b,L*C*h,XYZ,Yxy	CIE - L*a*b,L*C*h,XYZ,Yxy,Reflectance	
Other Index	Staining fastness, color fastness	WI(ASTM E313 - 10,ASTM E313 - 73,CIE/ISO,AATCC,Hunter, Taube Berger, Ganz, Stensby) YI(ASTM D1925, ASTM E313 - 00, ASTM E313 - 73)Tint(CIE,ASTM E313,Ganz)	metameric index Milm,staining fastness, color fastness	
Data storage	20000 test results			
Other functions	camera,electricity pantone color chart		camera,electricity pantone color chart, Mobile Phone APP	
Work temperature range	5~45 , relative humidity 80% or below( at 35 ° C ),no condensation			
Storage temperature range	-25 to 55 ,relative humidity 80% or below ( at 35 ° C ) ,no condensation			
Power source	Rechargeable lithium 8.4V/2000mAh , adaptor DC12V			
Size	77 x 86 x 210mm			
Weight	550g			
Color Matching System	not matching			
UV Light Source	excluded			

# Appearance and structure

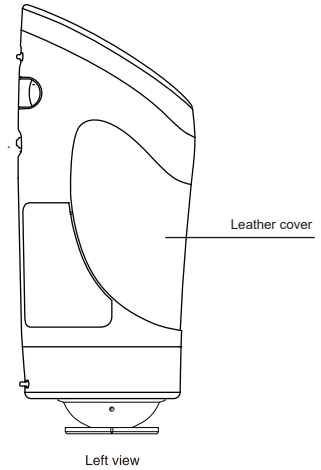
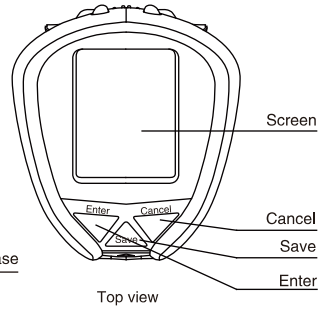
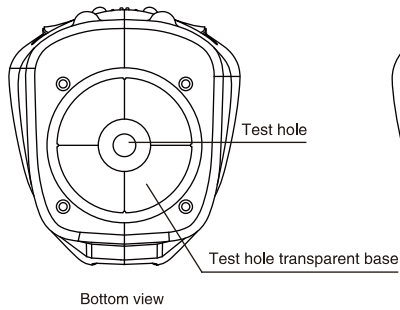
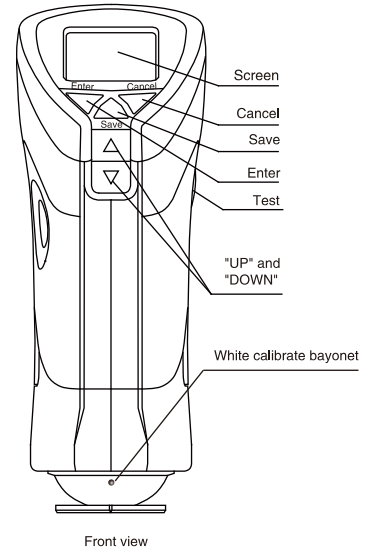
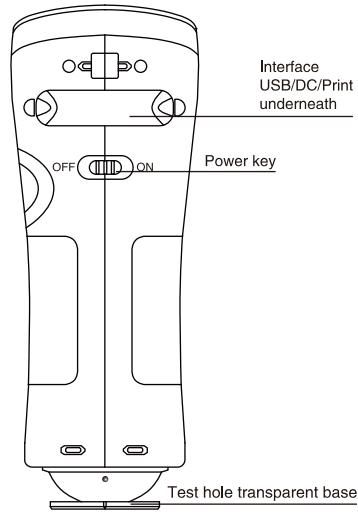
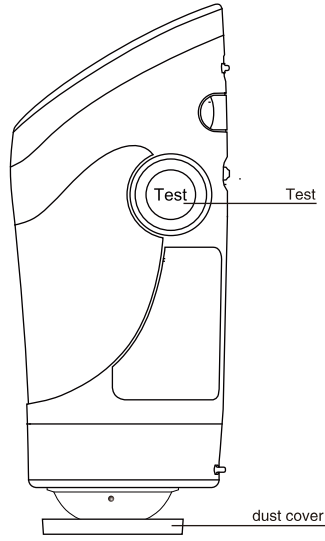

## Measuring flow chart

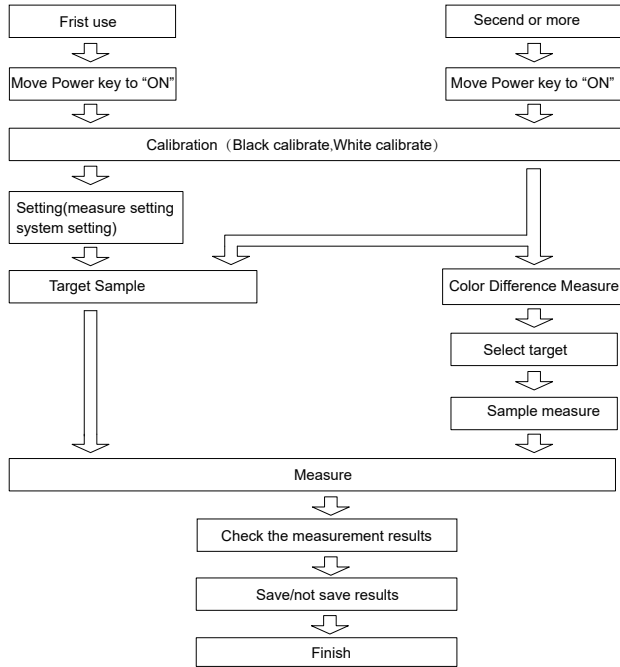

## Calibration page

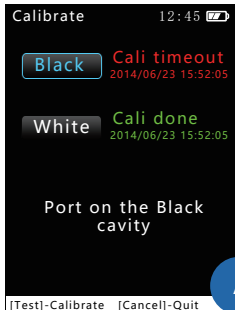

- A** Make sure the instrument works and move Power key to "ON".The instrument shows the starting page and transfers to calibrate page, under this page, calibrate the instrument.
- Pick off the dust cover and black cavity cover, put the bottom of instrument into black cavity and place evenly, Through the "Up", "Down" to choose "black calibration", press "Enter", we can do black calibration.

Put the instrument on the white tile properly. Press the "Up", "Down" to choose " White calibrate ", Press "Enter"to do "White calibrate".Press "Cancel" to exit the calibration page and enter the main page.

Annotation: In order to guarantee the stability of instrument, it is recommended that the "Black calibrate" and "White calibrate" must be completed complete every time when switch on the instrument.

## Main page

### A-1/1 Main page:

- ①title: display main function information of the current page
- ②working area: display main functions of the subordinate submenu or the testing data
- ③status bar: Guide the current operating situation

Basic operation method:

Press the "Up"and "Down" to choose function button, Press "Enter" button to

choose function interface to operation . press "Cancel" button to return to the last step, Press "Save" button to Save the result of the test or the state setting.

Measure: Users can measure sample each color parameters, complete samples and color difference between sample tests, and view the saved test records

Calibrate: User can do black and white calibration.

Data view: User can view the saved data. And could save, delete or edit the name of the sample.

Settings: User can select the parameters and other settings.

USB: USB interface is for PC connection of data transfer.

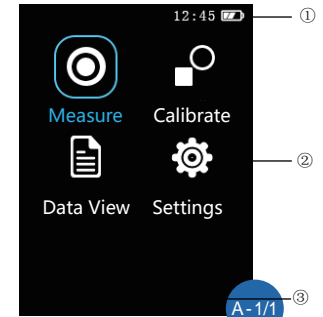

## Measure

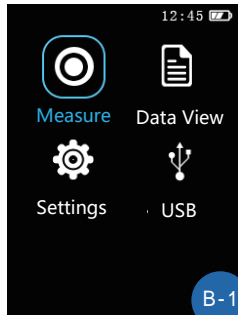

**B-1** The main page , press "up" or "down" to choose "Measure",press "Enter" into the "target measure"page. User can choose the parameters to measure, measure the target color value, whiteness and yellowness index. The color difference between target and sample can also be measured.

## Target measure

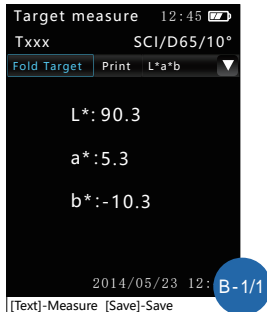

**B-1/1** Put the instrument test aperture on sample, press "test", then we can see the test result on screen.It shows the name of the sample and the test conditions in title bar. The target sample not saved, the name of target sample will be displayed as "Txxx".user can press "save" to rename and save the target sample. Test condition format: measuring condition /light/observer. Press "up" or "down"o choosse "Fold target","print"and display

content(include "L\*a\*b\*", "L\*C\*h", "X,Y,Z", "Y,x,y", "R,G,B").Press "Enter" to enter into sample measure page. User can compare the color difference between target and sample.

"print": print the result of the test data.

Chosse display content: press "enter" into the page , press "up" or "down" to choosse show different color parameters, include "L\*a\*b\*", "L\*C\*h", "X,Y,Z", "Y,x,y", "R,G,B".

## Sample measure

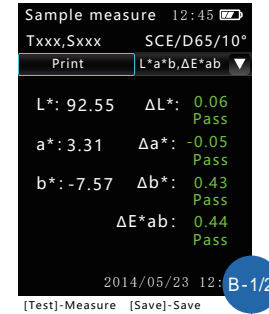

**B-1/2** In this page,user can measure the unknown sample to evaluate the color difference between the sample and the target by press button "Test".The name of the unknown sample displayed on the screen is "Sxxx" before saved. Users can also do the measurement in the page "Data View". Press the "Up", "Down" to choose the existing target,press"Enter" enter the options menu,choose" view details", view the selected target data,choose "Fold target",we will enter into the sample measure page.Press "test"to measure,the color difference measurement is finished. Press"Test" again for another sample color measurement.

Attention:Color tolarence should be set before color difference measurement.(Please refer to Setting→Meas Setup→tolarence).

In the page of"sample measure", press the "Up", "Down",user can print the color difference measure results. Choose the display content include "L\*a\*b\*", ΔE\*ab", "L\*C\*h, ΔEch", "X,Y,Z", "Y,x,y", "R,G,B", "WHITENESS", "YELLOW". Press "Up" and "Down" to select to view the content including color space, chrominance indicators, pass/fail, colour evaluation between the samples with the target sample.

## Data View

In the main page, press "Up", "Down" to choose the "Data View", press "Enter" to enter the page of "Data View". In this page, User can view the saved target, sample color simulation and so on.

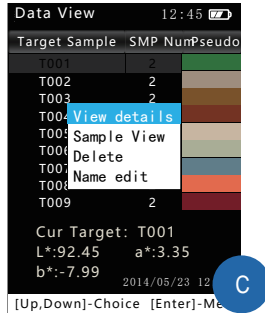

- C** Press the "Up", "Down" to choose the "Data View", press "Enter", Press "Up" and "Down" to choose view detail, check the sample name, delete, edit, and so on.
- View Details: look at all the detailed data for the selected target. Press "enter", user can measure the samples under the target sample, a new sample can be tested.
- Sample View: view all the sample under the selected target. Press "Enter" to choose view detail, delete, delete, delete all, name edit operation can be done.
- Delete: deletes all the color difference test records of the sample and the target sample.
- Rename: change the name of the selected samples.

## Settings

- D** On the main page, press "Up", "Down" to choose "Settings", press "Enter" to enter the settings page, include calibrate, meas setup, set time, power, reset all and language.

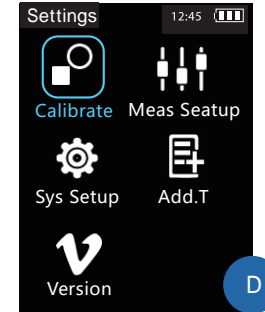

## Calibration

- E** In the main page, press "Up", "Down" to choose the "calibrate", press "Enter" to enter the page of "calibrate" in this page, user can choose "Black calibrate" and "White calibrate".

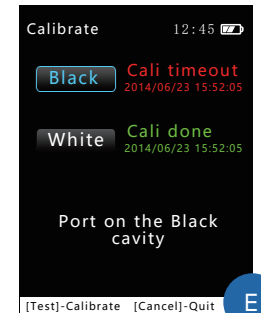

Take off the dust cover and black cavity cover, put the instrument into black cavity and place evenly, press "Up", "Down" to choose "black calibration", press "Enter", we will finish black calibration.

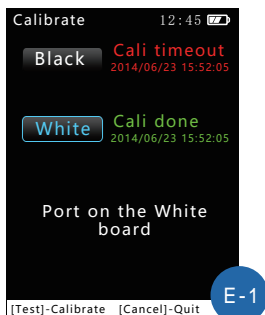

**E-1** White calibrate :Put the instrument on white calibration tile. Press the "Up", "Down" to choose " White calibrate ", Press "Enter"to "White calibrate".

## Measure settings

**F** Use "Up" and "Down" to select; press "Enter" to enter measurement setup page.

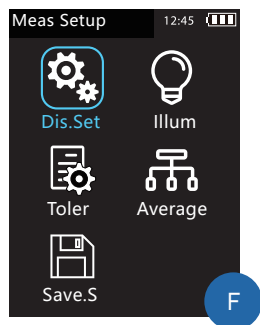

**F-1** Display settings: "Up"/ "Down" to select; "Enter" to enter display settings page. Press "Up" and "Down", select the color space, color values or indices you need, and confirm with "Enter" button. Then, the measurement page would show the color space you need.

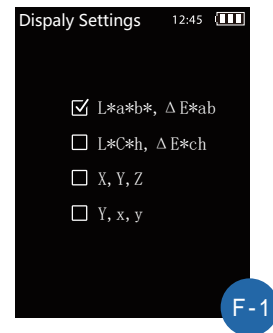

**F-2** Light source: Use "Up" and "Down" to select; press "Enter" to enter light source selection page. Under this page, you can toggle any light source that you wish to appear in the testing page, including A, C, D65 light sources. Use "Up", "Down" and "Enter" to toggle them.

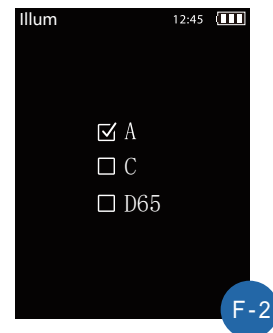

**F-3** Tolerance settings: Use “Up” and “Down” to select; press “Enter” to enter tolerance settings page. Use “Up” and “Down” to set the values and press “Enter” to confirm.

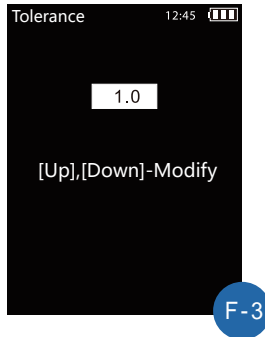

**F-5** Save setting: Use “Up” and “Down” to select; press “Enter” to enter “Save.S” page. Use “Up” and “Down” to select “Manual save” or “Auto save”, press “Enter” to confirm.  
Auto save: the target and sample measurement will be automatically saved and named every time (T040、S001).  
Manual save: the target and sample measurement will be saved and named by you (such as Txxx、Sxxx).

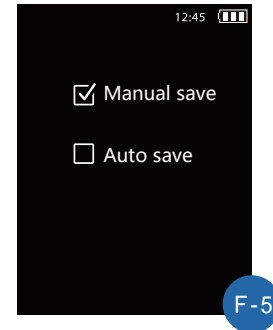

**F-4** Average settings: Use “Up” and “Down” to select; press “Enter” to enter average settings page. In this page, you set how many measurements does the “average test” makes before averaging to get the result. Use “Up” and “Down” to set the values and press “Enter” to confirm.

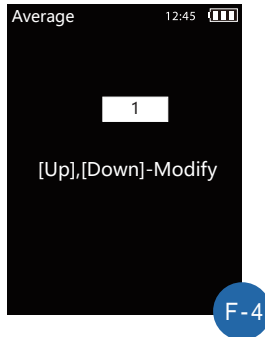

### System setup

**G** Use “Up” and “Down” to select; press “Enter” to enter system settings page. In the system settings page, you can enter these sub-pages: settings for language, time, power, reset all and view version.

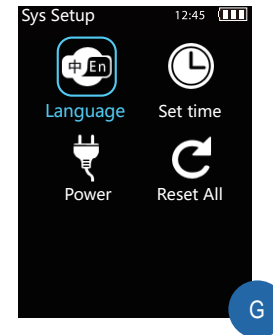

- G-1 Language selection: Use “Up” and “Down” to select; press “Enter” to enter language selection page. Use “Up” and “Down” to choose from the two languages this instrument supports: Chinese and English.



- G-3 Power: Use “Up” and “Down” to select; press “Enter” to enter power settings page. Use “Up” and “Down” to set backlight time and power off time. Use “Up” and “Down” to select the value you want to change and press “Enter”; then use “Up” and “Down” to set the value, press “Enter” to confirm. Finally, press “Cancel” to save the values or exit time setting.

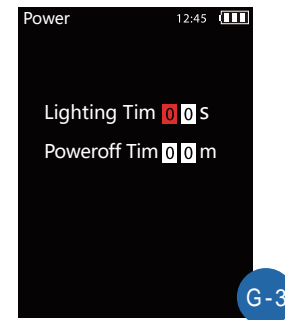

- G-2 Set time: Use “Up” and “Down” to select; press “Enter” to enter time settings page. Use “Up” and “Down” to select the value you want to change and press “Enter”; then use “Up” and “Down” to set the value, press “Enter” to confirm. Finally, press “Cancel” to save the values or exit time setting.

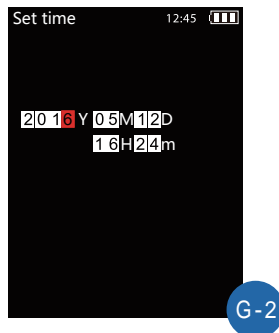

- G-4 Reset All: Use “Up” and “Down” to select; press “Enter” to enter reset all page. This action will delete all data and restore all to default settings.

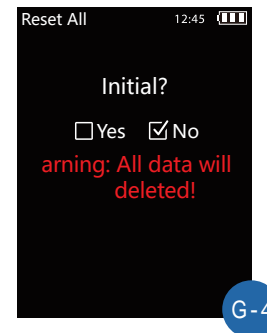

## Add.T

- H Add Target : Use “Up” and “Down” to select; press “Enter” to enter “Add.T”page. Press “Up” , “Down” and “Enter” , select the color space and enter the vale you need. Use “Up” and “Down” to choose “Add” and press “Enter” to confirm. After saving, simulation area can show the target color you added

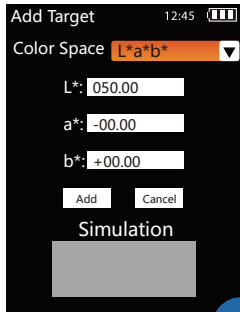

H

## Version

- I Version: Use “Up” and “Down” to select; press “Enter” to enter version page. In this page you can view the instrument’s model, product serial number, software version and company name. (Note: the software version may be subjected to change without notice)



I

## USB

- K In the main page, Use “Up” and “Down” to select; press “Enter” to enter USB connection page. Use the USB cable provided with the instrument to connect the instrument to PC. Install the driver program as instructed (driver program is in the CD provided with the instrument). The USB will be connected correctly after the driver program is installed, as shown in the following picture.

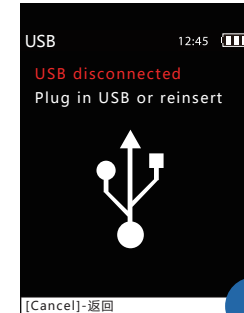

K

## Camera View

- L If instrument is with camera. In the "Measure" page, press "enter" we can view the measurement area by camera. Press "Cancel" to cancel the view function.
- L/1 For example in the sample test, long press "Enter" to view the measurement area.

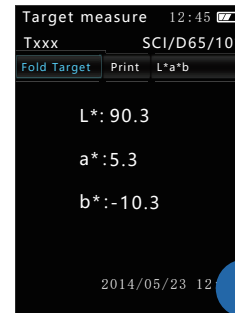

L

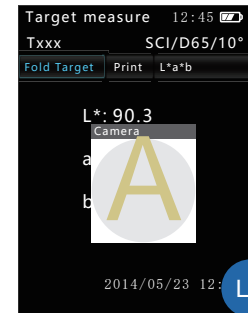

L/1

## Color Card Input

M-6

Double click the program “color card.exe”.

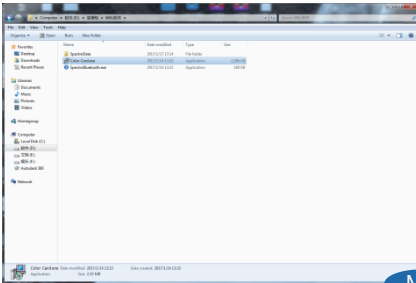

M-6

M-7

Choose the software language. Press “OK” to confirm your choice.

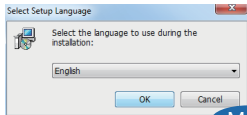

M-7/1

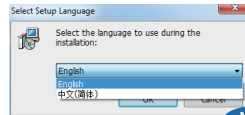

M-7/2

Enter into the software installation page, press “next” for installation.

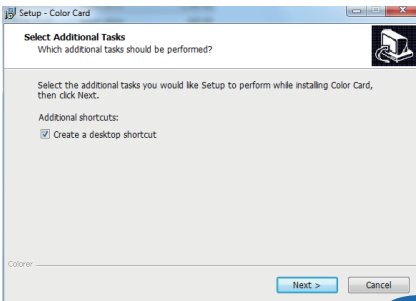

M-7/3

M-8

Click “install” to continue with the installation. After the installation finish, click “finish”.

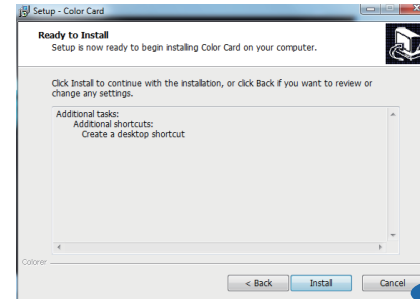

M-8/1

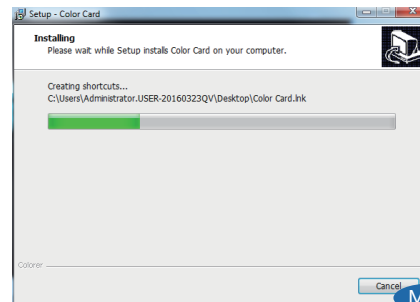

M-8/2

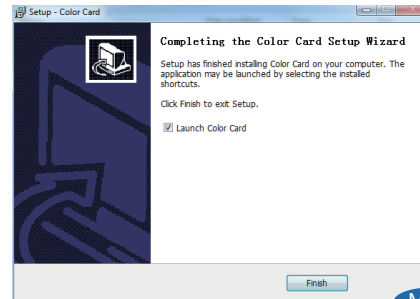

M-8/3

M-9

After installation, open the program "color card". The software is with "Pantone U" and "Pantone C 15".

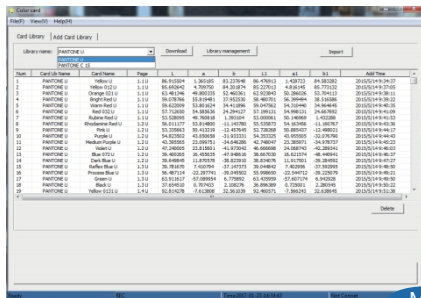

M-9

M-11

Input the color chart information including "library name", "card name", "card page", "row", etc.

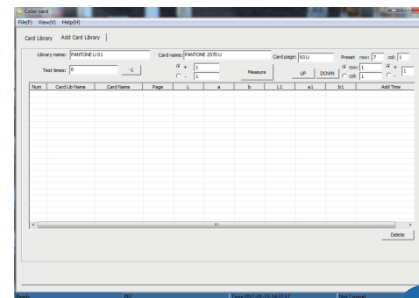

M-12

For example:  
Library name : Pantone U 01, Card Name: Pantone 2570U, Card Page:93U, Row:7, Col (column):1 Put the instrument testing aperture on the color swatch, click "measure" on the software or press "test" button on instrument for color measurement.

M-10

Connect the instrument with PC by USB cable. Click "add card library" to add color information.

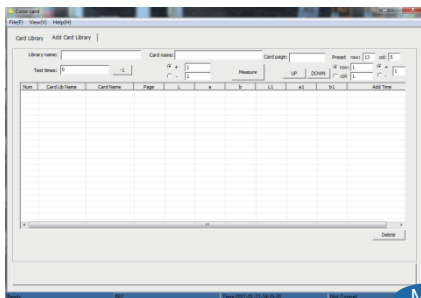

M-10

(Note: when measurement, instrument should be under USB interface, or the instrument can not connect with PC.)

After every measurement, the "measurement time", "color card name" number, "row" number and "col" number will increase or decrease according to the setting. As show in the figure, after measure 7 times, click "up" or "down" we could set the color card page number or we could change it and other data by manual.

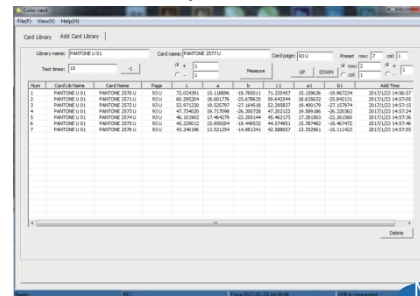

M-12

Add the card library according to the above instruction. After it is finished, we could download it into instrument. If we want to delete the card library, choose "library management", then click the card library name, at last press delete. Card library in format xml can be upload into software.

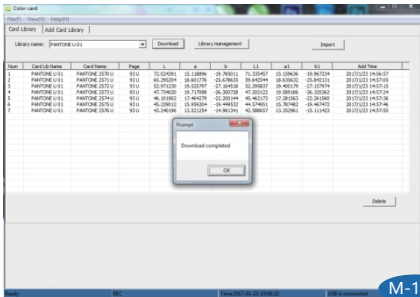

M-13-1

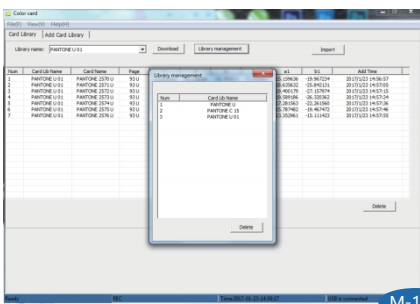

M-13-2

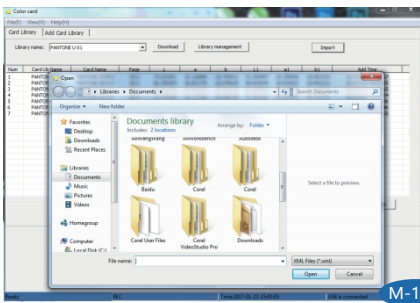

M-13-3

Accessories



PC software CD

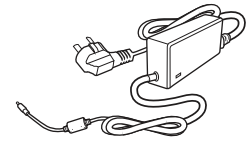

Adapter

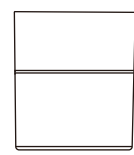

Black cavity for calibration

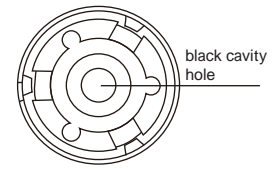

Top view for black cavity

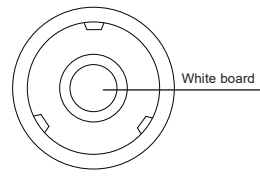

Top view for white board

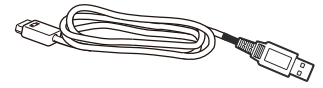

USB

Accessory list	
White Tile	used for white calibration.
Black cavity	used for black calibration.
External power supply	AC power adapter,with 2A rated current,5V required
CD	It contains the PC software.
USB Cable	communicate with PC
Micro printer	Optional accessories.Print the test result.

## Trouble Shooting

Trouble Shooting	Analysis
Unable to start instrument	1. Check instrument connects to power supply or not; 2. Check battery supply is sufficient or not.
Unable to enter main program after start	1. Check black and white calibration is done or not; 2. Check black and white calibration is correct or not.
Measurement data is wrong	Check <b>tolerance</b> is reasonable or not.
Measurement values abnormal	1. Check tested item is balance or not; check testing aperture force to tested surface properly or not; 2. Check tested item leak light or not; 3. Check tested item is <b>multi-color</b> or not.
Large difference between two measurement results	Check batteries power consumption <b>below 40%</b> or not.

## Testing Result Analysis

▼  $\Delta E^*ab$  Color Difference Scale 
$$\Delta E^*ab = \sqrt{(\Delta L^*)^2 + (\Delta a^*)^2 + (\Delta b^*)^2}$$

L+ represents white, L- represents black, a+ represents red, a- represents green, b+ represents yellow, b- represents blue. When we use CIE\*a\*b\* to show a color, L\* is black or white. a\* is red or green. b\* is yellow or green.

### ▼ CIE LAB

CIE LAB is color space based on the fact that a color can't be both red and green, or both blue and yellow, because these colors oppose each other. So a single data could be used to describe red/green and yellow/blue. When we use CIE L\*a\*b\* to describe a color, L\* means lightness, a\* means red/green and b\* means yellow/blue.

### ▼ CIE LCH

CIE LCH adopts same color space as L\*a\*b\*, but its L\* represents lightness, c\* represents saturation and h\* represents hue.

## Company's statement

1. The company promises that our colorimeter offers one year of warranty after purchase date. Non-artificial damage under normal use is subjected to free warranty. The company offers repair services for artificial damage, or damage after the warranty time limit; however, the repair services would require fees relative to the damage.
2. The warranty only holds for the person, or company who purchased the instrument. Damage occurring under third party usage would not be eligible for warranty service.
3. The company is not responsible for data loss because of error, repairing, or power outages. To prevent loss of important data, please save copies of the data on your PC.
4. The copyright ownership of the instrument and its associated software belong to our company and is protected by the Copyright Laws of People's Republic of China.
5. Our company sells the instrument does not mean we transfer the copyright, or any intellectual property's ownership to the user.
6. The specifications and information in this manual are subjected to further updates without notice.